

Speed: 1.0 m/s  
 PIT: 140 cm  
 OH=360 cm  
 FDmin.=250 (CH+50 cm)

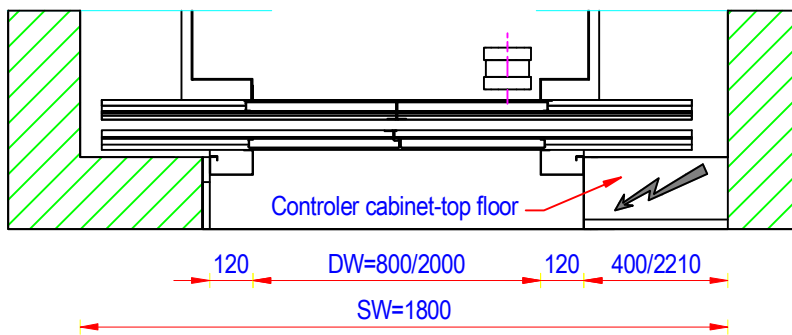

CW = Car width/Širina kabine  
 CD = Car depth/Dužina kabine  
 DW = Door width/Širina vrata  
 DH = Door height/Visina vrata  
 FD = Floor distance/Visina etaža  
 COP = Car Operating Panel  
 Kabinski panel  
 LOP = Landing Operating Panel  
 Spratni panel

TYPICAL REQUIREMENTS	
Motor Power kW	4.3 kW
Motor current	11 A