





OZ
pneumatica

*sposobnost
tehnologija
preciznost*

PROIZVODNI PROGRAM



AZ pneumatica



U svojim proizvodnim pogonima AZ Pneumatica raspolaže sa dva numerički upravljana struga i osam CNC obradnih centara koji omogućavaju visoku produktivnost, konstantnu preciznost izrade i visokokvalitetnu proizvodnju komponenata. Stopostotna izlazna kontrola gotovih proizvoda je naš najbolji znak pouzdanosti.

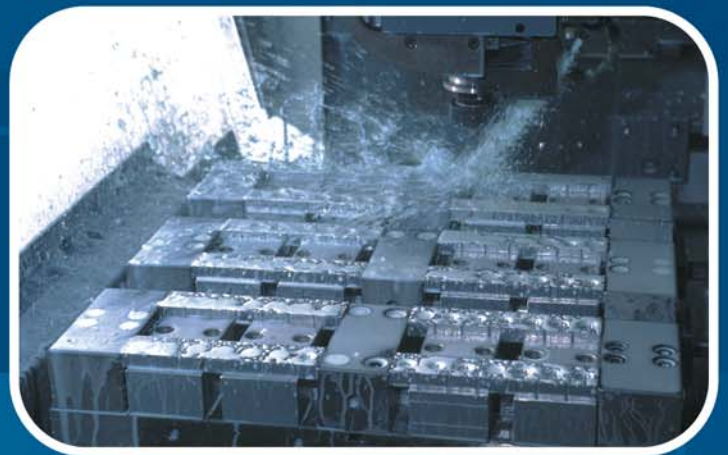



AZ Pneumatica s.r.l.

Via Kennedy, 26
20020 MISINTO (MI)
ITALIJA

Tel. +39-0296328519

Fax +39-0296720095

<http://www.azpneumatica.com>

Od svog osnivanja 1982. godine AZ Pneumatica proizvodi razvodnike, pneumatske cilindre i mnoge druge pneumatske komponente. Uz upotrebu najviših tehnologija AZ Pneumatica može danas ponuditi širok program proizvodnje koji će biti narednih godina dopunjavan novim proizvodima. Prodajna mreža pokriva čitavu Evropu i razvija se kako u EU tako i u ostalim evropskim državama.

Naši zastupnici omogućavaju najkraće rokove isporuke, nude kupcima kompetentnu tehničku podršku i daju kvalitetne odgovore na svako njihovo pitanje.







MEHANIČKI AKTIVIRANI RAZVODNICI





 ø4
304 MA
 M5
305 MA





 ø4
304 MR
 M5
305 MR





 ø4
304 MS
 M5
305 MS



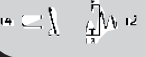

 ø4
304 MV
 M5
305 MV



G1/8"
 **321 MP**
 **521 MP**



G1/8"
 **321 MPS**
 **521 MPS**



G1/8"
 **321 MR**
 **521 MR**



G1/8"
 **321 MRU**
 **521 MRU**



G1/8"
 **321 MRS**
 **521 MRS**



G1/8"
 **321 MN**
 **521 MN**



G1/8"
 **431 MR**
 **451 MR**





G1/8"
 **431 MR**
 **451 MR**





G1/8"
 **431 MRL**
 **451 MRL**

RUČNO AKTIVIRANI RAZVODNICI

 ø4
304 MB
 M5
305 MB



 ø4
304 MGG
304 MGR
304 MGV
304 MGN





 G1/8"
431 MGG
431 MGR
431 MGV
431 MGN





 G1/8"
451 MGG
451 MGR
451 MGV
451 MGN



 M5
305 LL



 G1/8"
321 MB

521 MB



 G1/8"
321 MB90

521 MB90



RM 010



RM 050 R



RM 300 N







 G1/4"
PED 502 M

PED 502 B



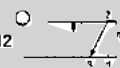



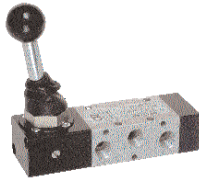

 ø4
PED 304 M

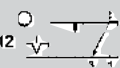



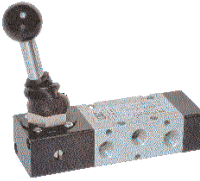

 G1/8"
321 ML90

 G1/4"
322 ML90

 G1/8"
521 ML90

 G1/4"
522 ML90

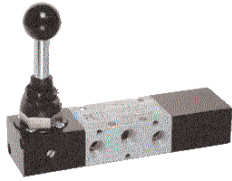





 G1/8"
321 LL90

 G1/4"
322 LL90

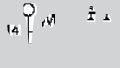
 G1/8"
521 LL90

 G1/4"
522 LL90







 G1/8"
5213C LL90
5213A LL90
5213P LL90

 G1/4"
5223C LL90
5223A LL90
5223P LL90

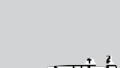

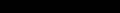



 G1/8"
5213C ML90
5213A ML90
5213P ML90

 G1/4"
5223C ML90
5223A ML90
5223P ML90

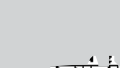

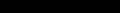



 G1/8"
321 MT

 G1/4"
322 MT

 G1/8"
521 MT

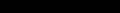
 G1/4"
522 MT



 G1/8"
321 TT

 G1/4"
322 TT

 G1/8"
521 TT

 G1/4"
522 TT



 G1/8"
321 LL

 G1/4"
322 LL

 G1/8"
521 LL

 G1/4"
522 LL



 G1/8"
5213A ML



PNEUMATSKI AKTIVIRANI RAZVODNICI



G1/8"
321 MC
G1/4"
322 MC
G1/8"
521 MC
G1/4"
522 MC



G1/8"
321 CC
G1/4"
322 CC
G1/8"
521 CC
G1/4"
522 CC



G1/8"
5213C CC
5213A CC
5213P CC
G1/4"
5223C CC
5223A CC
5223P CC

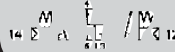

ISO 1
152 MC
152 CFP
152 CC

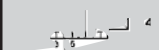
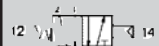

ISO 1
153C CC
153A CC
153P CC

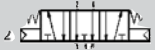
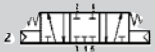

NAMUR
382 MC



NAMUR
582 CC



VDMA 18 mm
851 MC
851 CFP
851 CC

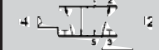

VDMA
18 mm

18 mm
G1/8"
731 MC



18 mm
G1/8"
751 MC

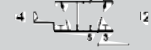

18 mm
G1/8"



8513C CC
8513A CC

7513C CC
7513A CC

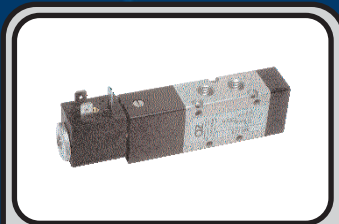

G1/8"

321 ME

G1/4"

322 ME

G1/8"

521 ME

G1/4"

522 ME

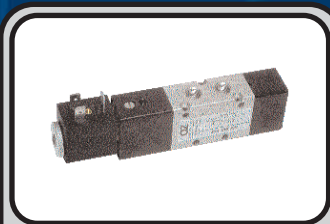

G1/8"

321 ME AS

G1/4"

322 ME AS

G1/8"

521 ME AS

G1/4"

522 ME AS



G1/8"

321 EE

G1/4"

322 EE

G1/8"

521 EE

G1/4"

522 EE

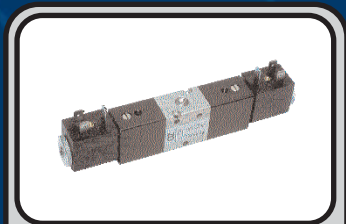
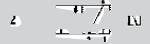

G1/8"

321 EE AS

G1/4"

322 EE AS

G1/8"

521 EE AS

G1/4"

522 EE AS

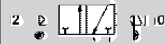

G1/8"

5213C EE

5213A EE

5213P EE

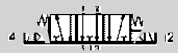
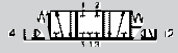

G1/4"

5223C EE

5223A EE

5223P EE



G1/8"

5213C EE AS

5213A EE AS

5213P EE AS

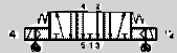

G1/4"

5223C EE AS

5223A EE AS

5223P EE AS



ISO 1

152 ME

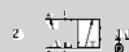
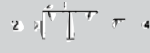

152 ME AS



ISO 1

152 EE



152 EE AS



ISO 1

153C EE

153A EE

153P EE



ISO 1

153C EE AS

153A EE AS

153P EE AS

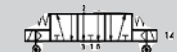
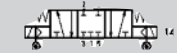

NAMUR

382 ME



582 ME



NAMUR

382 EE

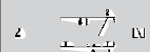

582 EE



ELEKTROMAGNETNI RAZVODNICI



VDMA 18 mm



851 ME

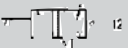

851 EFP

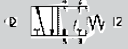

851 ME AS



VDMA 18 mm



851 EE



851 EE AS



VDMA
18 mm



8513C EE
8513A EE



VDMA
18 mm



8513C EE AS
8513A EE AS



18 mm
G1/8"



751 ME



751 EFP



751 ME AS



18 mm
G1/8"



751 EE



751 EE AS

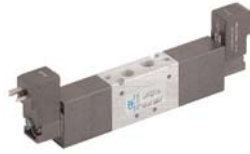

18 mm
G1/8"



7513C EE
7513A EE



18 mm
G1/8"

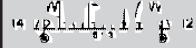

7513C EE AS
7513A EE AS



18 mm
G1/8"



731 ME

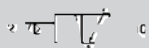

731 EFP



731 ME AS



18 mm
G1/8"



731 EE



731 EE AS



G1/8"

NC: **00.051.3**
NA: **00.088.3**

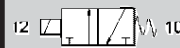

G1/4"

NC: **01.005.3**
NA: **01.066.3**





OR $\varnothing 4$
08.021.4
 M5
08.022.4
 G1/8"
08.023.4



AND $\varnothing 4$
08.025.4
 M5
08.026.4
 G1/8"
08.027.4



NOT
 $\varnothing 4$
08.039.4

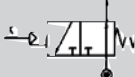

YES
 $\varnothing 4$
08.049.4

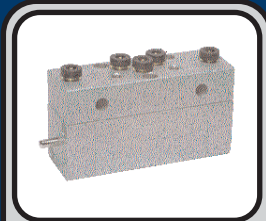
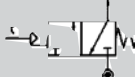

memorijski element
 $\varnothing 4$
04.003.4
04.002.4



OR
 G1/8"
08.133.4
 G1/4"
08.127.4

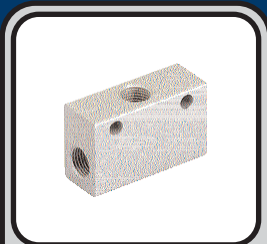

AND
 G1/8"
08.121.4

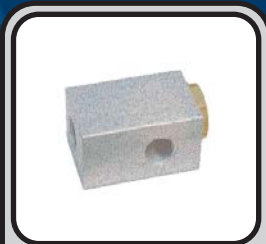

brzoispusni ventil
 G1/8"
08.180.4
 G1/4"
08.181.4

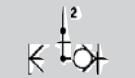

G1/8": **AZ-CRS1**
 G1/4": **AZ-CRS2**
 G3/8": **AZ-CRS3**
 G1/2": **AZ-CRS4**



prekidač
 G1/8"
TRP 8



RFU M5
RFU 1/8.2
RFU 1/8.3
RFU 1/4
RFU 3/8
RFU 1/2

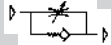

RFB M5
RFB 1/8
RFB 1/4
RFB 3/8
RFB 1/2



VNR M5 FF
VNR 1/8 FF
VNR 1/8 MF
VNR 1/4 FF
VNR 1/4 MF



RSW 1/8
RSW 1/4
RSW 3/8
RSW 1/2



RSTC 1/8
RSTC 1/4



razdeljivači



presostati





INTEGRIRANI ELEMENTI

oscilator



01.044.4
01.046.4
01.008.3

flip-flop



01.040.4
01.028.3

dvopritisni ventil



00.047.4
00.008.3
10.007.4
10.006.3

generator impulsa



NO: 10.001.4
NC: 10.009.4

slow-start ventil

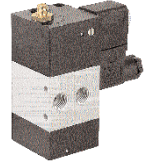

10.003.3

vakum generator



DP 2010 E

vakum generator sa nepovratnim ventilom



DP 2018 F

vakumski raspršivač



DP 2005

sigurnosni dvoručni ventil



08.156.4

tajmer za automatski povratni hod cilindra



00.074.4



G1/8"
11.044.4



G1/8"
11.066.4



cilindri ISO 6431 VDMA



ø32 ... ø200

KIT cilindri ISO 6431



ø32 ... ø200

filteri



G1/4" **FIL 2-25-S**
 G3/8" **FIL 3-30-S**
 G1/2" **FIL 4-30-S**
 G1" **FIL 6-30-S**

regulatori pritiska



G1/4" **REG 2-08**
 G3/8" **REG 3-08**
 G1/2" **REG 4-08**
 G1" **REG 6-10**

zauljivači



G1/4" **LUB 2-00**
 G3/8" **LUB 3-00**
 G1/2" **LUB 4-00**
 G1" **LUB 6-00**

filter regulatori



G1/4" **FR 2-08-25-S**
 G3/8" **FR 3-08-30-S**
 G1/2" **FR 4-08-30-S**
 G1" **FR 6-10-30-S**

FR+L



G1/4" **FR+L 2-08-25-S**
 G3/8" **FR+L 3-08-30-S**
 G1/2" **FR+L 4-08-30-S**
 G1" **FR+L 6-10-30-S**

FRL



G1/4" **FRL 2-08-25-S**
 G3/8" **FRL 3-08-30-S**
 G1/2" **FRL 4-08-30-S**
 G1" **FRL 6-10-30-S**

shut-off ventil



G3/8" **SR M-3**
 G1/2" **SR M-4**
 G1" **SR M-6**

brzoispusni ventil



G3/8" **SCR 3-E**
 G1/2" **SCR 4-E**

slow-start ventil



G3/8" **AVP 3-00**
 G1/2" **AVP 4-00**

proporcionalni regulator pritiska



G3/8" **RPE 3 V NC**
RPE 3 V NA
 G1/2" **RPE 4 V NC**
RPE 4 V NA

PNEUMATSKI CILINDRI

mikrocilindri ISO 6432



ø10 ... ø25

okrugli cilindri



ø32 ... ø63

kompaktni cilindri



ø32 ... ø100

kratkohodni cilindri



ø16 ... ø100