

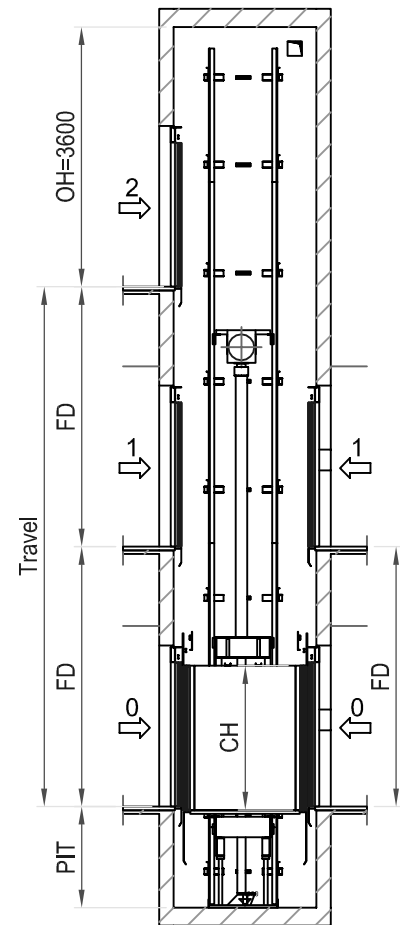

HYDRAULIC LIFTS HIDRAULIČNI LIFT

Version: 2.0

Date: 20.03.11

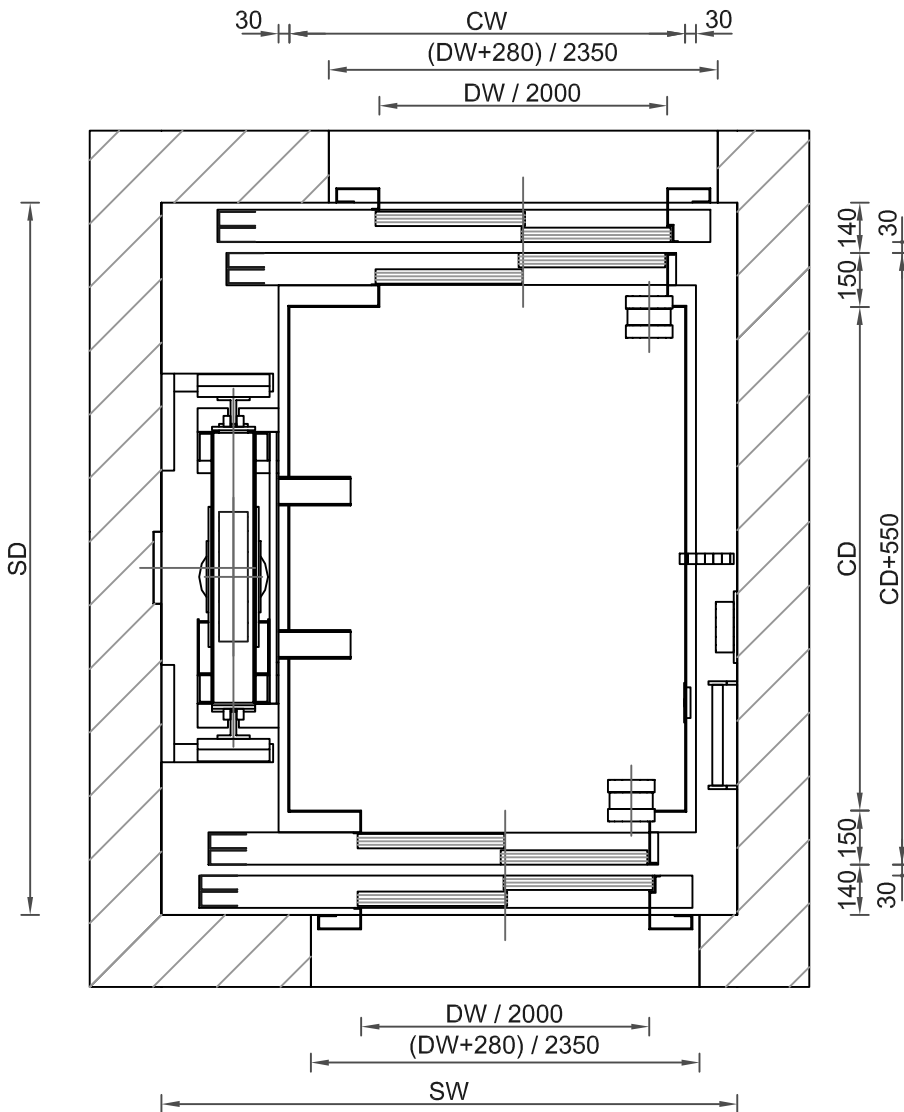

- CW = Car width/Širina kabine
- CD = Car depth /Dužina kabine
- DW = Door width/Širina vrata
- DH = Door height/Visina vrata
- FD = Floor distance/Visina etaža
- COP = Car Operating Panel/
Kabinski panel
- LOP = Landing Operating Panel/
Spratni panel

Speed: 0.63 m/s
PIT: 140 cm
OH=360 cm

FD_{min.}=250 (CH+50 cm)

RATED LOAD NOSIVOST kg	PERSONS BROJ OSOBA	CAR DIMENSIONS DIMENZIJE KABINE		SHAFT DIMENSIONS mm DIMENZIJE VOZNOG OKNA mm		DOOR VRATA DW mm	DOOR HEIGHT VISINA VRATA DH mm	JAMA OKNA PIT mm
		CW	CD	SW	SD			
320	4	900	1000	1400	1550	700	2000	1200
450	6	1000	1200	1500	1750	800	2000	1400
630	8	1100	1400	1600	1950	800	2000	1400